

IDEAL SOLAR
MOUNTING SYSTEM
FOR FLAT ROOFS

Mounting instructions

EasyWest

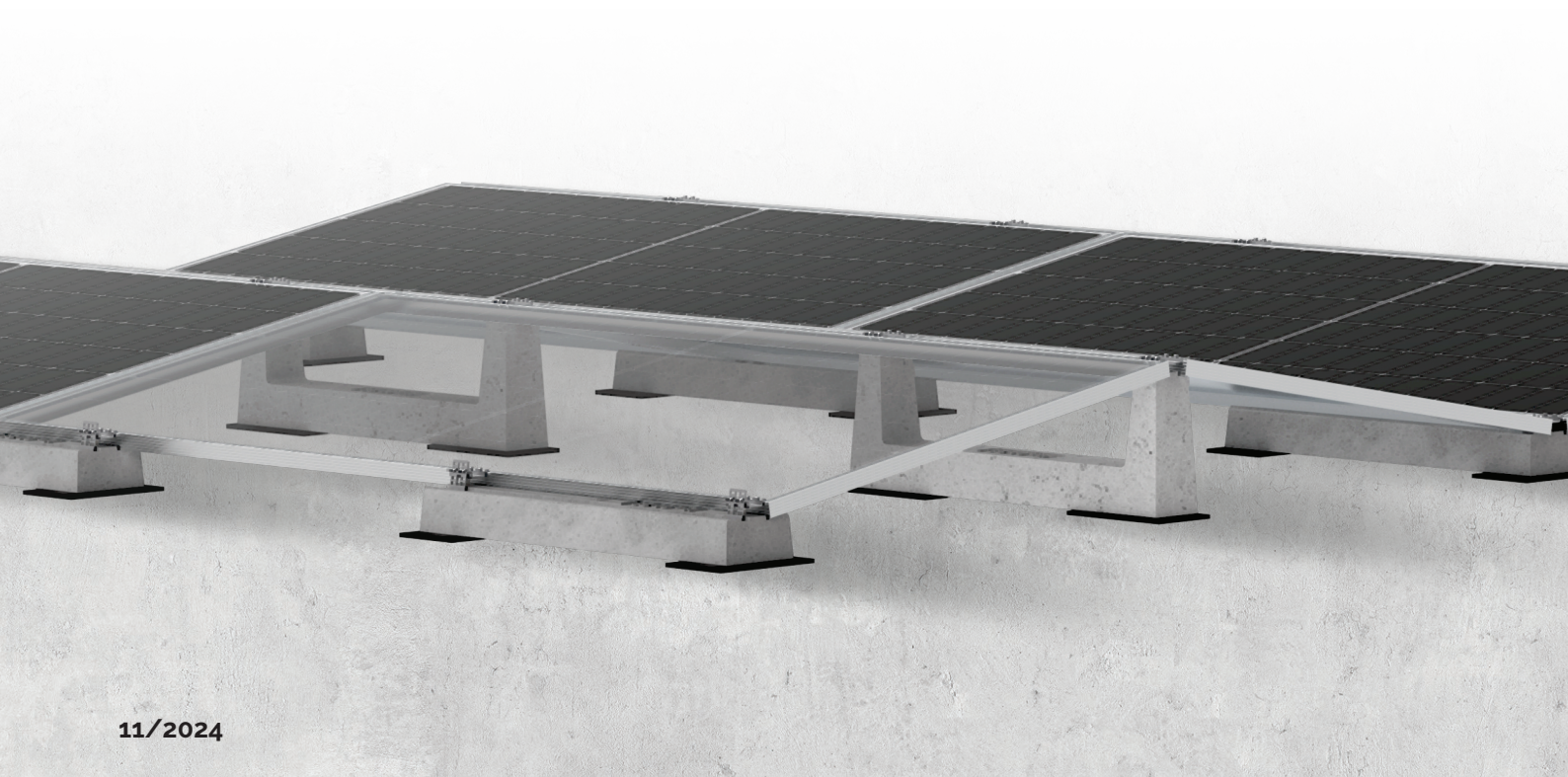
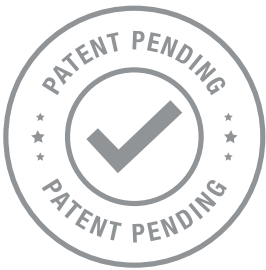

Ballast 23010.EV

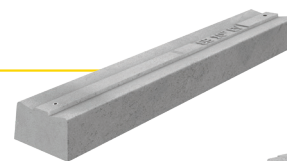

Ballast 23010.EP

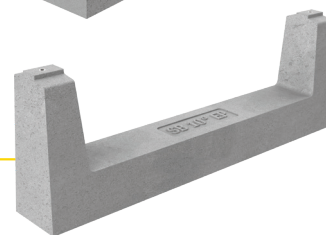

Membrane KGN23115



Clamp K23900/PWC-EV.40

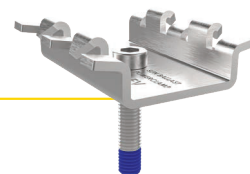

Clamp K23900/PWC-EP.40

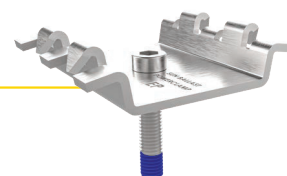

End plate 23920/PWC

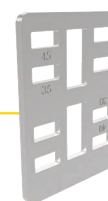

MOUNTING INSTRUCTIONS

- Use a tightening torque of 12-14 Nm, in accordance with the specifications in the technical data sheet for the panel used;
- All measurements relating to ballasts are provided in the technical data sheet for the system employed;
- For any additional information, contact the Sun Ballast Technical Department.

- 1 Trace out the perimeter of the installation on the roof, using a chalk line.

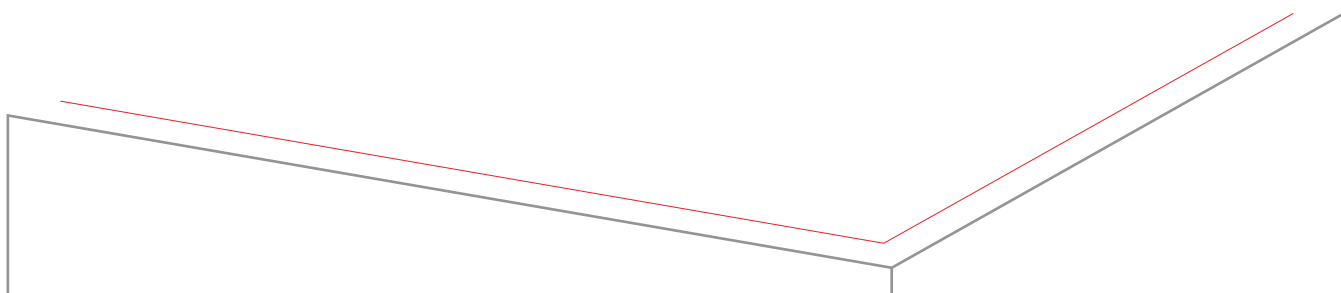

- 2 Position the first row of membranes, taking into account the dimensions of the structures and the spacing between them. (The membranes must be arranged with the long side perpendicular to the line along which the ballasts will be placed)

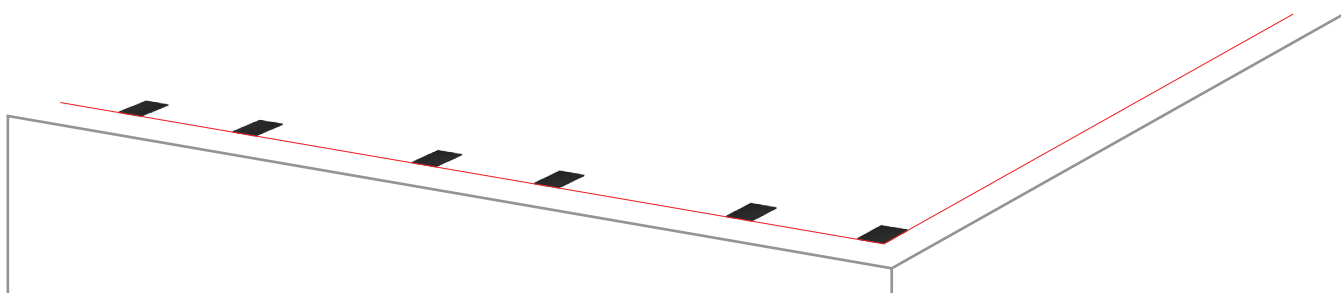

- 3 Place the first row of EV ballasts on the membranes. The spacing between the structures should be such that each ballast – except for the end ones – is halfway between two panels. The centre of the EV ballast is indicated by two raised lines.

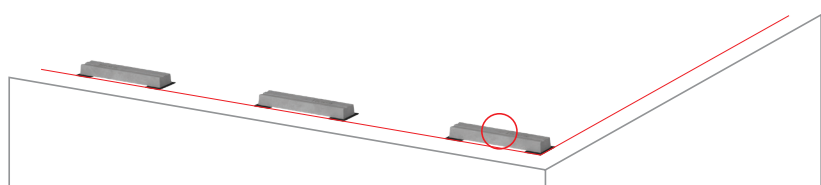

- 4** Align the second row of membranes with the previous ones, but placing the long side rotated by 90° (that is, parallel to the EV ballasts).

The spacing between the two rows of membranes depends on the dimensions of the panel used.

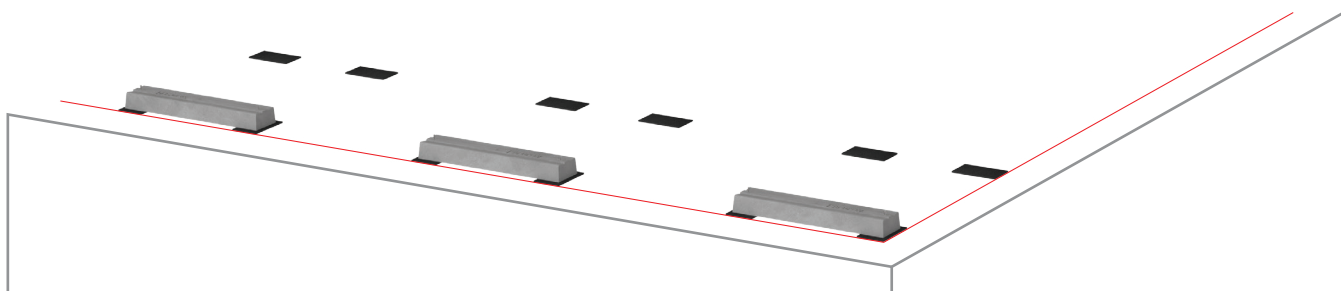

- 5** Place the EP ballasts aligned with the membranes, checking for correct alignment with the structures of the structures of the previous row.

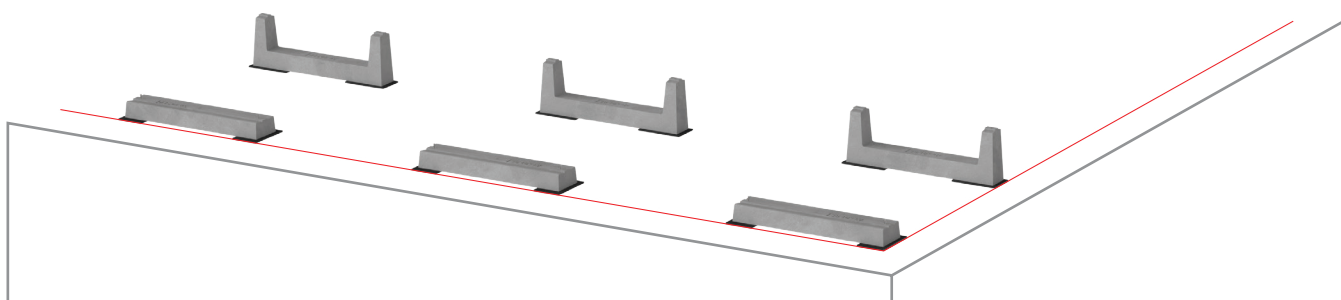

- 6** Position the first row of panels, aligning the sides of the frame with the grooves on the ballasts. Check that the corner of the modules coincides with the centre of the EV ballasts, and is halfway along the EP ballasts

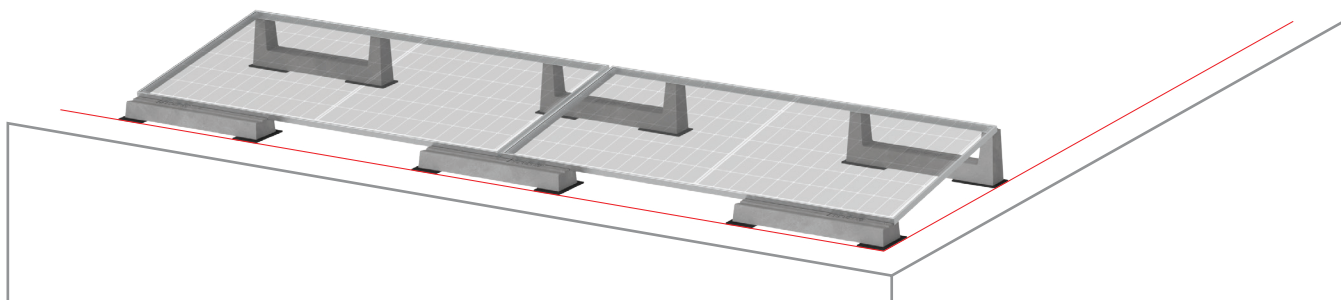

- 7** Secure the panels onto the EV ballasts using the end clamps (clamp 23900/PWC.EV + plate 23920/PWC).
If available, use a torque wrench, applying a torque between 12 and 14 Nm, as specified in the technical data sheets of the modules.

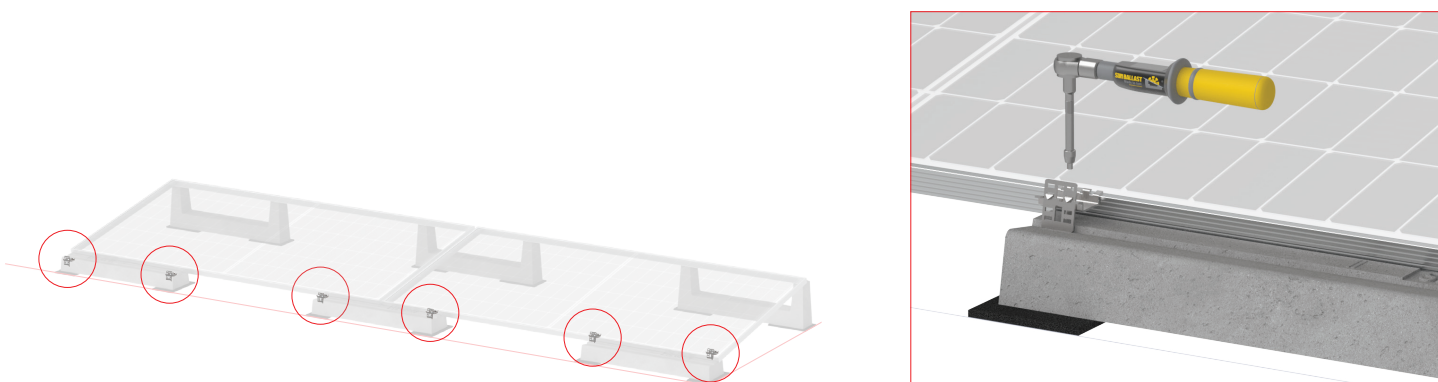

- 8** Position the third row of membranes, checking for alignment and placing them in the same direction as used for the first row (EV ballasts).

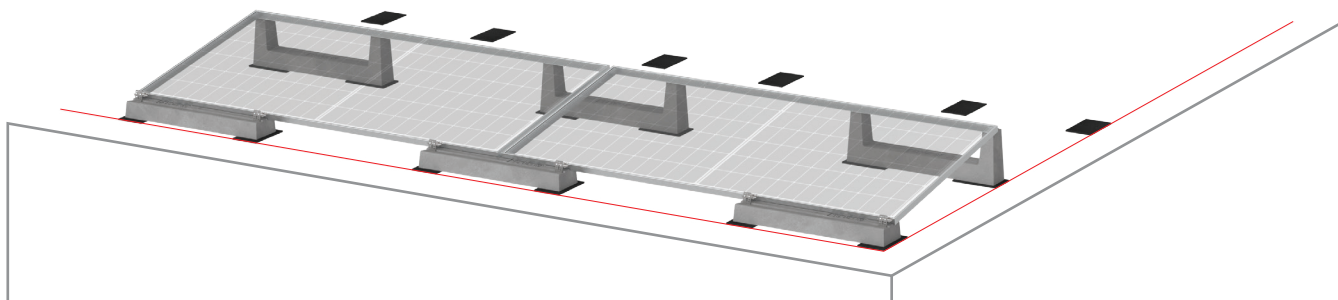

- 9** Position the third row of ballasts (EV) aligned with the membranes.

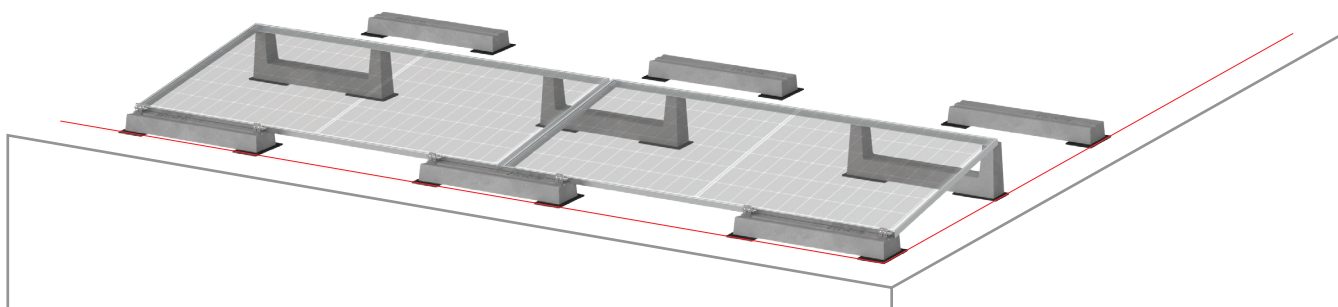

- 10** Place the first panel of the second row aligned with the grooves on the ballasts.
If necessary, adjust the spacing between the structures, bringing the frame flush against the ballasts.

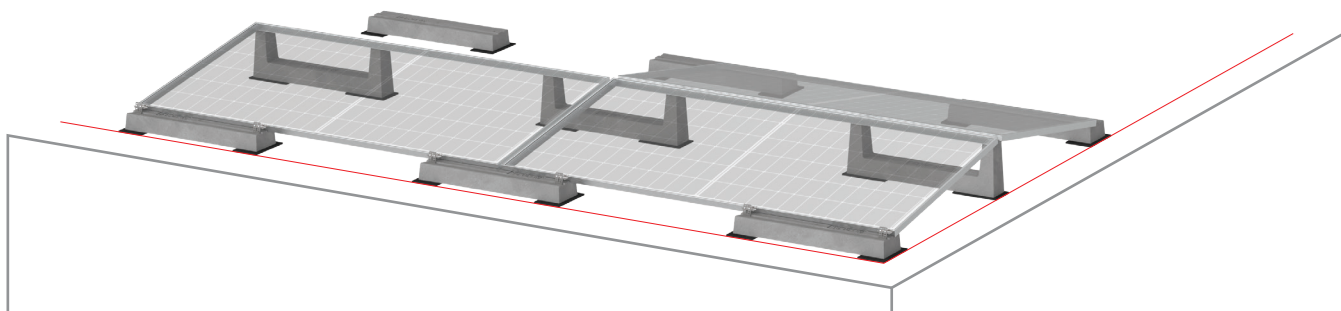

- 11** Secure the first panel of the second row on the EP ballasts using clamps 23900/PWC.EP.
If available, use a torque wrench, applying a torque between 12 and 14 Nm, as specified in the technical data sheets of the modules.

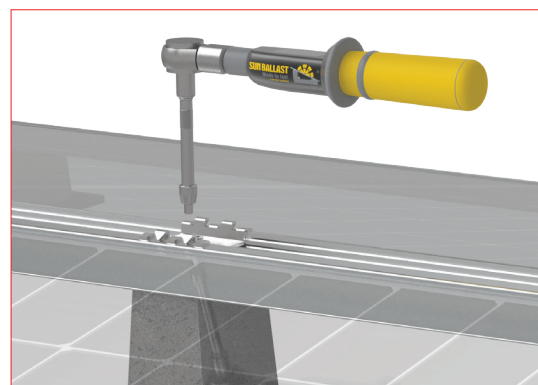
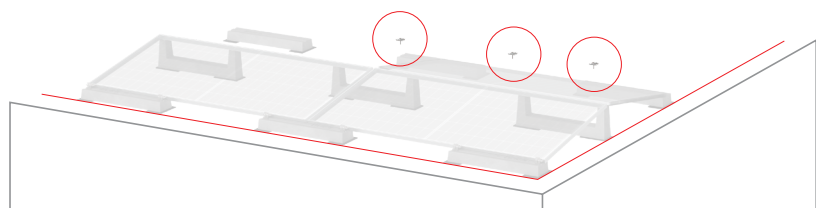

- 12** Secure the second panel of the second row on the EP ballasts using clamps 23900/PWC.EP.
Continue securing one panel at a time until the entire row is complete.
Follow the torque specifications outlined in the previous points.

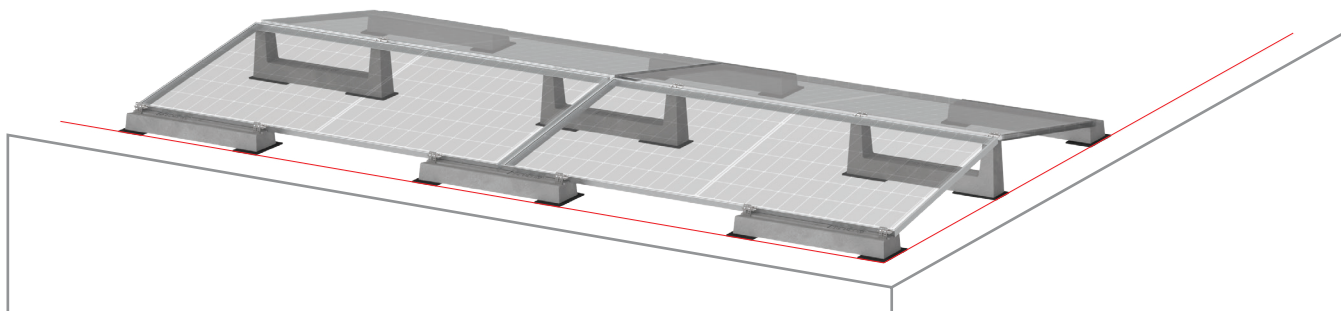

- 13** Position the fourth row of membranes, making sure they are aligned with the previous ones, and placing them in the same direction as used for the second row (EP ballasts).

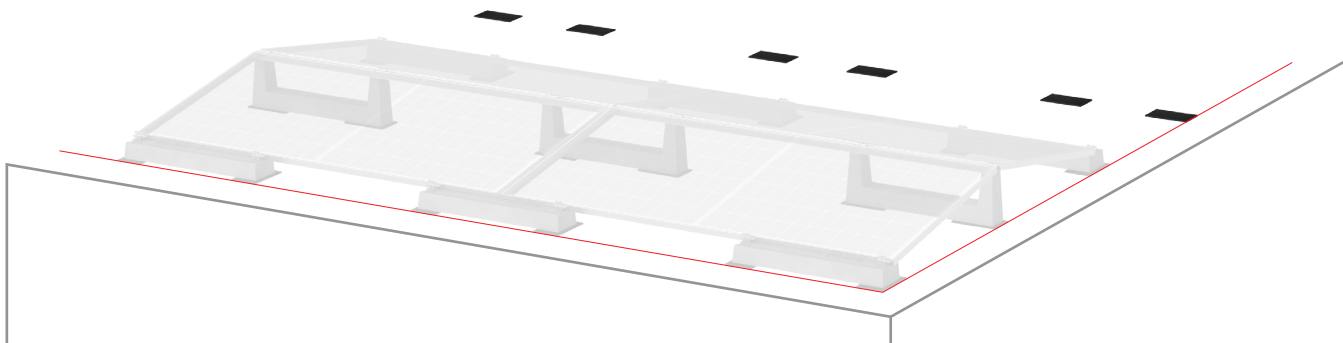

- 14** Position the fourth row of ballasts (EP) aligned with the membranes.

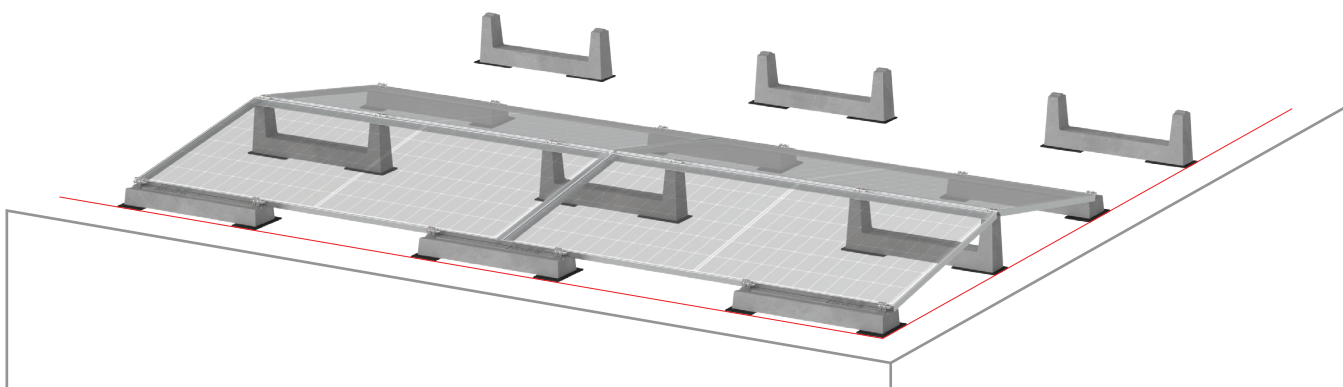

- 15** Place the first panel of the third row aligned with the grooves on the ballasts. If necessary, adjust the spacing between the structures, bringing the frame flush against the ballasts. Then, secure the panel on the EV ballast with clamps 23900/PWC.EV and proceed by securing one module at a time until the row is complete.

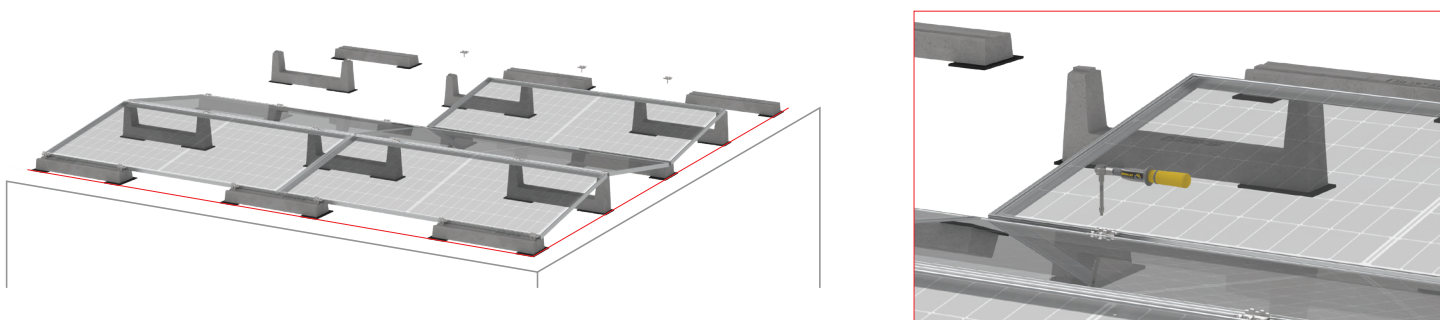

- 16** Repeat the above-listed operations for all the subsequent rows until the installation is complete.
The clamps used in the last row of ballasts must be secured using the end plates (23920/PWC).

